

SUBMITTAL/TECHNICAL DATA SHEET



SPECIFICATIONS

MATERIAL:
 • UL-SEE: 16 gauge galvanized steel
 • UL-SEEA: .090 aluminum

FINISH:
 • Galvanized Steel: Mill Finish
 • Aluminum: Mill Finish

COVER: Damage resistance, light admitting, 1/8" polycarbonate outer dome with 1/8" polycarbonate inner dome, surrounded by an extruded aluminum frame.

CURB: 13 1/2" in height with 3 1/2" pre-drilled mounting flanges and counterflashing with 1" thick exterior fiberboard insulation

GASKET: Polyurethane Foam Gasket adhered to the entire perimeter of curb

HINGES: Steel Pintle Hinge

SPRINGS: Torsion Coil Spring operators to open against a 10 psf snow or wind load

DAMPENERS: Hydraulic dampeners to control cover opening speed and prevent over travel

LATCHES: Latch designed to open automatically with parting of single 165 degree fusible link or manually with interior and exterior pull release handles without disturbing the fusible link. Designed to withstand 90 psf wind uplift for class 90 roof decks

HARDWARE: All hardware is zinc plated (stainless steel hardware optional)

OPERATION: Covers automatically spring open to approximately 90 degrees in the event of fire, being actuated by the parting of a single UL-listed 165 degree F fusible link, automatically locking in the fully opened position

CERTIFICATIONS:
 • UL 793 Listed
 • UL 790 Certified



SKU: **UL SEEA**
DOMESMOKE VENT



DIMENSIONS AND APPEARANCE

>> CLICK TO VIEW ADDITIONAL DETAILS AND PRICING <<

STANDARD SIZES AND PRODUCT NUMBER:

| MODEL | SIZES WXH | LBS. | MODEL | SIZES WXH | LBS. |
|--------------|-------------|------|--------------|-------------|------|
| UL-SEEA-4848 | 4'0" X 4'0" | 225 | UL-SEEA-6084 | 5'0" X 7'0" | 440 |
| UL-SEEA-4860 | 4'0" X 5'0" | 270 | UL-SEEA-6096 | 5'0" X 8'0" | 505 |
| UL-SEEA-4872 | 4'0" X 6'0" | 315 | UL-SEEA-6648 | 5'6" X 4'0" | 320 |
| UL-SEEA-4884 | 4'0" X 7'0" | 355 | UL-SEEA-6660 | 5'6" X 5'0" | 375 |
| UL-SEEA-4896 | 4'0" X 8'0" | 405 | UL-SEEA-6672 | 5'6" X 6'0" | 425 |
| UL-SEEA-5448 | 4'6" X 4'0" | 250 | UL-SEEA-6684 | 5'6" X 7'0" | 485 |
| UL-SEEA-5460 | 4'6" X 5'0" | 305 | UL-SEEA-6696 | 5'6" X 8'0" | 550 |
| UL-SEEA-5472 | 4'6" X 6'0" | 340 | UL-SEEA-7248 | 6'0" X 4'0" | 355 |
| UL-SEEA-5484 | 4'6" X 7'0" | 415 | UL-SEEA-7260 | 6'0" X 5'0" | 410 |
| UL-SEEA-5496 | 4'6" X 8'0" | 465 | UL-SEEA-7272 | 6'0" X 6'0" | 460 |
| UL-SEEA-6048 | 5'0" X 4'0" | 285 | UL-SEEA-7284 | 6'0" X 7'0" | 530 |
| UL-SEEA-6060 | 5'0" X 5'0" | 340 | UL-SEEA-7296 | 6'0" X 8'0" | 615 |
| UL-SEEA-6072 | 5'0" X 6'0" | 385 | | | |

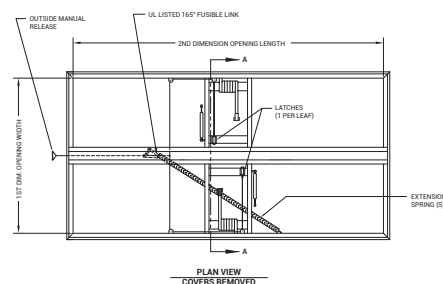

Check the Second Page for more Detailed Information

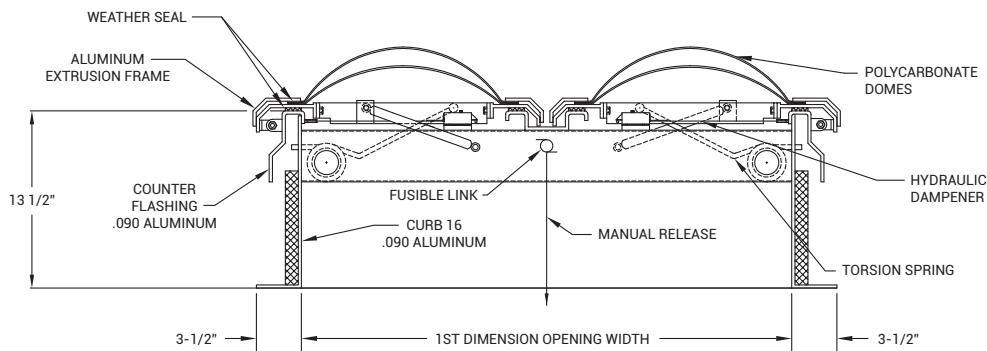

SECTION VIEW A-A

For a complete list of options visit www.AccessDoorsAndPanels.com

PROJECT DATA

Custom Sizes Available - Fast!

| | | | | |
|------------------------|--|---|---|---------|
| PROJECT NAME : | QTY | W | H | OPTIONS |
| ARCHITECT : | | | | |
| DEALER : | | | | |
| CONTRACTOR : | | | | |
| LOCATION : | SPECIAL INSTRUCTIONS : | | | |
| DATE : | SUBMITTAL APPROVAL : (signature or stamp) | | | |
| TAGGING INSTRUCTIONS : | | | | |

Scan or Click



To view Pricing and Additional Product Info.

TELEPHONE:
1-888-457-1275
FAX:
1-888-626-2907

PO BOX 66738 #76520,
SAINT LOUIS, MO
63166-6738
USA



WEBSITE:
www.AccessDoorsAndPanels.com
E-MAIL:
info@accessdoorsandpanels.com



UL SEEA

**DOOMED SKYLIGHT
SMOKE VENT**

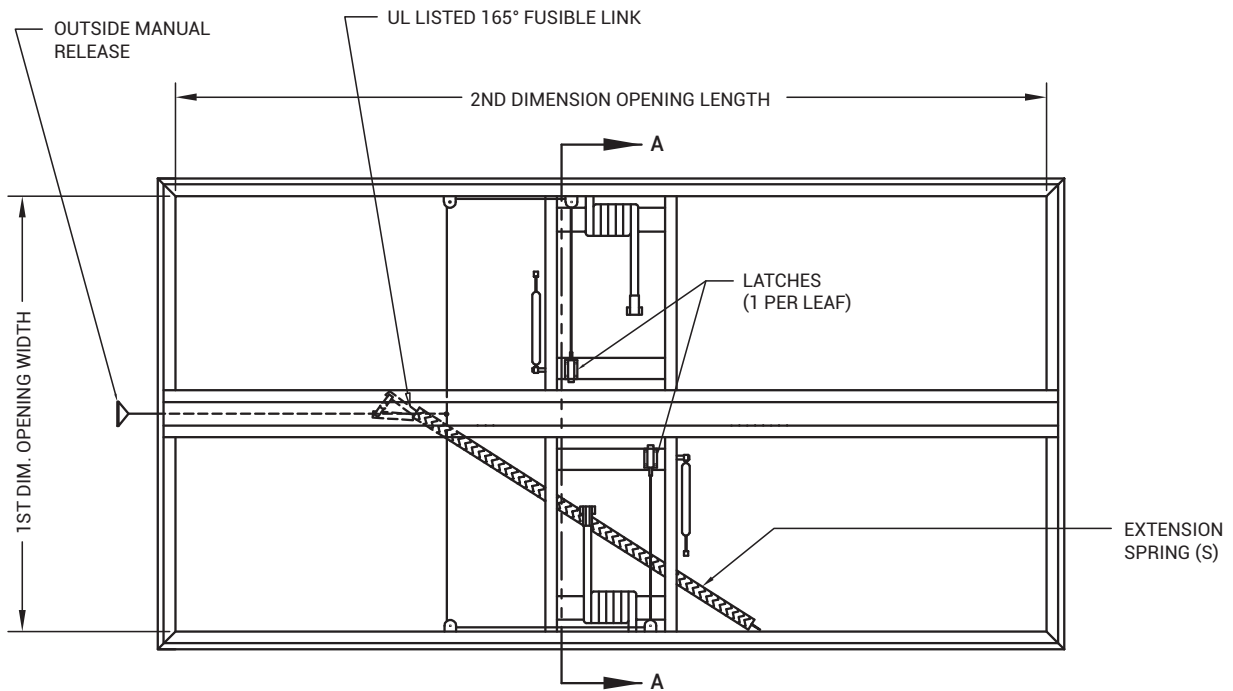

**PLAN VIEW
COVERS REMOVED**

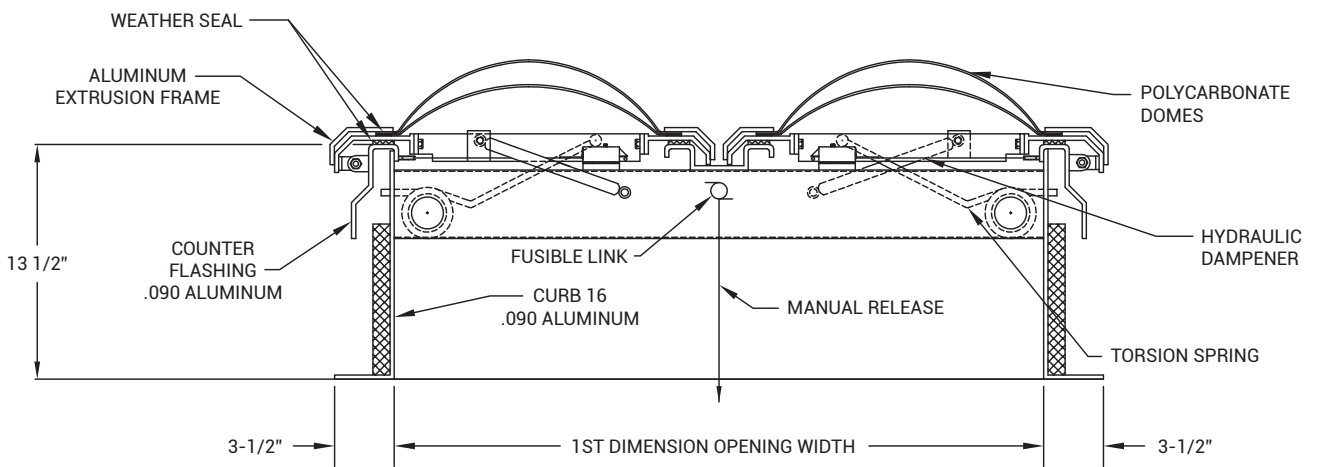

SECTION VIEW A-A

NOTES:

- LISTED BY UNDERWRITERS LABORATORIES (UL 793)
- RATED TO OPEN AGAINST 10 PSF SNOW/WIND LOAD
- RATED TO REMAIN CLOSED AGAINST 30 PSF UPLIFT LOAD
- 25 FT OF CABLING PROVIDED FOR INTERIOR RELEASE